

Orgatower



10year
warranty

Scocca esterna (fianchi, coperchio, fondo e schiena)

melaminico: in truciolare (densità 720 kg/m³, emissione di formaldeide classe E1, soddisfa i requisiti previsti dal CARB), sp. 18 mm, nobilitati con resine melaminiche antiriflesso e bordati in ABS sp. 2 mm con spigoli raggianti sui lati a vista e in ABS sp. 0,45 mm sugli altri lati.

I fianchi sono dotati di piedini in acciaio rivestiti in polietilene dotati di regolazione massima di + 8 mm per il livellamento a pavimento. La scocca va completata con top di finitura (sp. 18 o 25 mm), fioriera o doxbox.

Scocca interna estraibile (fianchi, coperchio, fondo e schiena)

melaminico: in truciolare (densità 720 kg/m³, emissione di formaldeide classe E1, soddisfa i requisiti previsti dal CARB), sp. 18 mm per coperchio, fianchi e fondo e sp. 12 mm per la schiena, nobilitati con resine melaminiche antiriflesso, bordati in ABS sp. 0,45 mm. Ogni fianco è dotato di doppia foratura (passo 32 mm) per l'aggancio dei ripiani. La scocca è montata su guide a sfera ad estrazione totale, installate sulla scocca esterna e dotate di ammortizzatore in chiusura. Sulla parte frontale vi è una ruota (Ø 75 mm) in gomma termoplastica per pavimenti duri, montata su una staffa in lamiera d'acciaio, che serve a sostenere il peso del mobile quando l'estraibile è in posizione aperta. La scocca è dotata di stabilizzatori anteriori e posteriori per allineare lo scorrimento dell'estraibile, e di ammortizzatore in apertura montato sul coperchio della scocca esterna.

Ripiani

melaminico: in truciolare (densità 720 kg/m³, emissione di formaldeide classe E1, soddisfa i requisiti previsti dal CARB), sp. 25 mm, nobilitati con resine melaminiche antiriflesso e bordati in ABS sp. 0,45 mm con spigoli raggianti. L'Orgatower H. 72 cm ha un ripiano mentre quello H. 112 cm ha 2 ripiani di serie.

Top di finitura

melaminico: in truciolare (densità 720 kg/m³, emissione di formaldeide classe E1, soddisfa i requisiti previsti dal CARB), sp. 18 o 25 mm (a seconda dell'altezza della scrivania), nobilitato con resine melaminiche antiriflesso e bordato in ABS sp. 2 mm con spigoli raggianti. Viene fissato alla parte superiore della scocca tramite viti da legno.

Frontale

melaminico: in truciolare (densità 720 kg/m³, emissione di formaldeide classe E1, soddisfa i requisiti previsti dal CARB), sp. 18 mm nobilitati con resine melaminiche antiriflesso e bordati in ABS sp. 2 mm con spigoli raggianti. Il frontale viene fissato alla scocca interna estraibile. È dotato di maniglia verticale centrale (interasse 256 mm) e di serratura con cilindro estraibile per permettere la variazione della cifratura. Vengono forniti con 2 chiavi operative di cui una pieghevole.

Orgatower

External structure (sides, top, bottom and back)

melamine: made of 18 mm th. chipboard (density 720 kg/m³, formaldehyde emission class E1, meets CARB requirements), faced with anti-reflex melamine resins and edged with 2 mm th. ABS with rounded edges on visible sides and 0.45 mm thick ABS on the other sides. The sides are fitted with polyethylene-coated steel feet with a maximum adjustment of + 8 mm for floor levelling. An 18- or 25-mm th. finishing top, plant box or doxbox must be added to the structure.

Pull-out internal structure (sides, top, bottom and back)

melamine: 18 mm th. chipboard for top, side and bottom and 12 mm th. for back (density 720 kg/m³, formaldehyde emission class E1, meets CARB requirements), covered with anti-reflex melamine resins, edged with 0.45 mm thick ABS. Each side is equipped with double perforations (32 mm pitch) for attaching shelves. The structure is mounted on full-extension ball-bearing runners, installed on the external structure and equipped with closing damper. On the front of the internal structure there is a castor (Ø 75 mm) made of thermoplastic rubber for hard floors, mounted on a steel sheet bracket that is used to support the weight of the cabinet when the pull-out elements are open. The structure is equipped with front and rear stabilisers to align the sliding of the pull-out element and has an opening damper fitted on the lid of the external structure.

Shelves

melamine: made of 25 mm th. chipboard (density 720 kg/m³, formaldehyde emission class E1, meets CARB requirements), covered with anti-reflex melamine resin and edged with 0.45 mm th. ABS with rounded edges. The H. 28"3/8 Orgatower has 1 shelf while the H. 44"1/8 one has 2 shelves as standard.

Finishing top

melamine: made of 18 or 25 mm th., depending on the desk's height, chipboard (density 720 kg/m³, formaldehyde emission class E1, meets CARB requirements), covered with anti-reflex melamine resins and edged with 2 mm th. ABS with rounded edges. It is fixed to the upper part of the structure by means of wood screws.

Front panel

melamine: made of 18 mm th. chipboard (density 720 kg/m³, formaldehyde emission class E1, fulfils CARB requirements), covered with anti-reflex melamine resin and edged with 2 mm th. ABS with rounded edges. The front panel is attached to the internal pull-out structure. It's equipped with a central vertical handle (centre distance 256 mm) and with a lock with extractable cylinder to allow the variation of the code. They are supplied with 2 operating keys, one of which is foldable.

Structure externe (côtés, couvercle, fond et dos)

melamine: réalisé en aggloméré (densité 720 kg/m³, émission de formaldéhyde classe E1, répondant aux exigences du CARB), ép. 18 mm, recouvert de résines mélaminées antireflet et bordé en ABS ép. 2 mm arrondi sur les côtés visibles et en ABS ép. 0,45 mm sur les autres côtés. Les côtés sont équipés de patins en acier revêtus de polyéthylène avec un réglage maximum de + 8 mm pour la mise au niveau. La structure doit être complétée par un dessus de finition, ép. 18 ou 25 mm, un bac à fleur ou doxbox.

Structure interne extractible (côtés, couvercle, fond et dos)

melamine: réalisé en aggloméré (densité 720 kg/m³, émission de formaldéhyde classe E1, répondant aux exigences du CARB), ép. 18 mm pour le couvercle, les côtes et le fond, et ép. 12 mm pour le dos, recouvert de résines mélaminées antireflet et bordé en ABS ép. 0,45 mm. Chaque côté est équipé d'un double perçage (pas 32 mm) pour l'accrochage des étagères. La structure est montée sur des glissières à billes à extraction totale, installées sur la structure extérieure et équipées de amortisseurs en fermeture. Sur la partie frontale il y a une roulette (Ø 75 mm) en caoutchouc thermoplastique pour sols durs, fixée sur un support en tôle d'acier qui sert à supporter le poids de la structure interne lorsqu'elle est en position ouverte. La structure est équipée de stabilisateurs antérieurs et postérieurs pour aligner le glissement de l'extractible, et d'un amortisseur en ouverture monté sur le dessus de la structure externe.

Étagères

melamine: réalisé en aggloméré (densité 720 kg/m³, émission de formaldéhyde classe E1, répondant aux exigences du CARB), ép. 25 mm, recouvert de résines mélaminées antireflet et bordé en ABS ép. 0,45 mm arrondi. L'Orgatower Ht. 72 cm est équipé d'une étagère tandis que celui Ht. 112 cm est équipé de 2 en standard.

Dessus de finition

melamine: réalisé en aggloméré (densité 720 kg/m³, émission de formaldéhyde classe E1, répondant aux exigences du CARB), ép. 18 ou 25 mm (en fonction de la hauteur du bureau), recouvert de résines mélaminées antireflet et bordé en ABS ép. 2 mm arrondi. Il est fixé à la partie supérieure de la structure à l'aide de vis à bois.

Façades

melamine: réalisé en aggloméré (densité 720 kg/m³, émission de formaldéhyde classe E1, répondant aux exigences du CARB), ép. 18 mm recouvert de résines mélaminées antireflet et bordé en ABS sp. 2 mm arrondi. La façade est fixée à la structure interne extractible. Elle est dotée d'une poignée verticale en position centrale (entraxe 256 mm) et d'une serrure avec cylindre extractible pour permettre la variation du chiffreage. Elles sont fournies avec 2 clés opérationnelles dont une pliable.

Orgatower

Orgatower
Orgatower
Orgatower

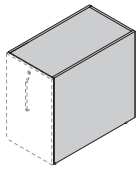

M - Scocca in melaminico - Melamine structure - Structure en mélamine



MBI - Bianco
White - Blanc



MWP - Bianco perla
Pearl white
Blanc nacré



MAH - Alluminio
Aluminium
Aluminium



MTR - Tortora
Dove - Gris taupe



MCE - Cemento
Concrete - Béton
TEXTURE MATERICA
TEXTURED EFFECT



MOB - Olmo chiaro
Light elm
Orme clair



MRO - Rovere
Oak - Chêne



MNC - Noce
Walnut - Noyer



MFN - Frassino nero
Black ash
Frêne noir



MNV - Nero velluto
Black velvet
Velours noir

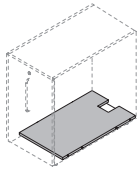

M - Fondo scocca in melaminico - Melamine bottom structure - Fond du meuble en mélamine



MAH - Alluminio
Aluminium
Aluminium

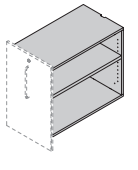

M - Scocca estraibile in melaminico - Melamine pull-out structure - Structure extractible en mélamine

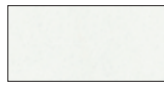

MBI - Bianco
White - Blanc



MAH - Alluminio
Aluminium
Aluminium



MNV - Nero velluto
Black velvet
Velours noir

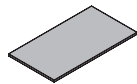
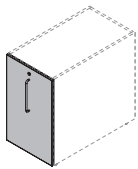

M - Top e frontali in melaminico - Melamine top and fronts - Dessus et façades en mélamine



MBI - Bianco
White - Blanc



MWP - Bianco perla
Pearl white
Blanc nacré

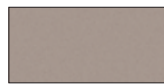

MTR - Tortora
Dove - Gris taupe



MCE - Cemento
Concrete - Béton
TEXTURE MATERICA
TEXTURED EFFECT

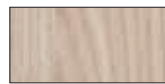

MOB - Olmo chiaro
Light elm
Orme clair



MRO - Rovere
Oak - Chêne

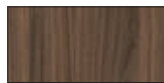

MNC - Noce
Walnut - Noyer



MFN - Frassino nero
Black ash
Frêne noir



MNV - Nero velluto
Black velvet
Velours noir

Maniglia in metallo
Metal handle
Poignée en métal

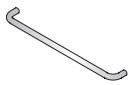

MET - Metallo - Metal - Métal



AO - Alluminio
Aluminium
Aluminium

Orgatower

Doxbox
Doxbox
Doxbox

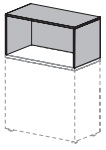

M - Scocca in melaminico - Melamine structure - Structure en mélamine

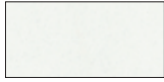

MBI - Bianco
White - Blanc



MAH - Alluminio
Aluminium
Aluminium



MNV - Nero velluto
Black velvet
Velours noir

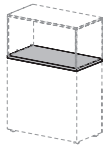

M - Top di finitura in melaminico - Melamine finishing top - Dessus de finition en mélamine

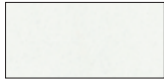

MBI - Bianco
White - Blanc



MWP - Bianco perla
Pearl white
Blanc nacré

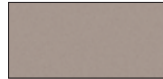

MTR - Tortora
Dove - Gris taupe

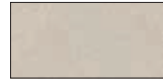

MCE - Cemento
Concrete - Béton
TEXTURE MATERICA
TEXTURED EFFECT

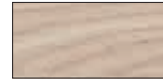

MOB - Olmo chiaro
Light elm
Orme clair

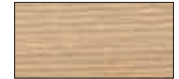

MRO - Rovere
Oak - Chêne



MNC - Noce
Walnut - Noyer



MFN - Frassino nero
Black ash
Frêne noir



MNV - Nero velluto
Black velvet
Velours noir

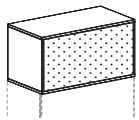

Schiena in melaminico rivestita in tessuto - Fabric upholstered melamine back - Dos en mélamine revêtu en tissu



Cat. D



Cat. F

Fioriera - Contenitore in melaminico sovrapponibile a mobile - (Non a tenuta stagna)

Plant box - Melamine container stackable on cabinet - (Not leakproof)

Bac à fleur - Conteneur en mélamine superposable à l'armoire - (Non étanche)

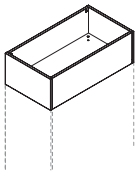

M - Melaminico - Melamine - Mélamine



MBI - Bianco
White - Blanc

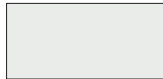

MWP - Bianco perla
Pearl white
Blanc nacré

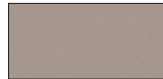

MTR - Tortora
Dove - Gris taupe

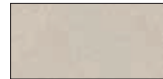

MCE - Cemento
Concrete - Béton
TEXTURE MATERICA
TEXTURED EFFECT

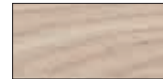

MOB - Olmo chiaro
Light elm
Orme clair

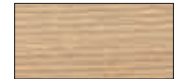

MRO - Rovere
Oak - Chêne

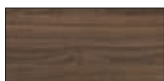

MNC - Noce
Walnut - Noyer



MFN - Frassino nero
Black ash
Frêne noir



MNV - Nero velluto
Black velvet
Velours noir

Cassetto porta cancelleria

Stationery drawer

Tiroir plumier

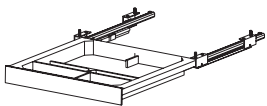

PL - Plastica - Plastic - Plastique



NE - Nero
Black - Noir

Orgatower

Dati tecnici
Technical data
Données techniques

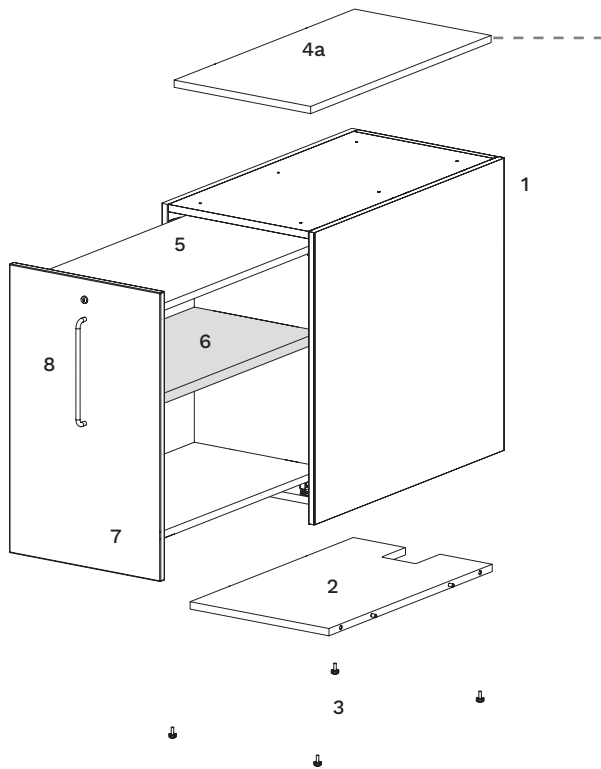

1. Scocca esterna
External structure
Structure externe

2. Fondo
Bottom
Base

3. Piedini
Feet
Patins

4. Elemento di completamento - Obbligatorio
Finishing element - Compulsory
Élément de finition - Obligatoire

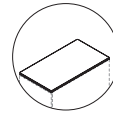

4a. Top di finitura
Finishing top
Dessus de finition

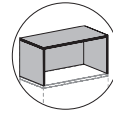

4b. Doxbox
Doxbox
Doxbox

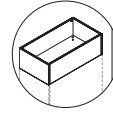

4c. Fioriera
Plant box
Bac à fleur

Elemento estraibile
Pull-out element
Élément extractible

5. Scocca interna estraibile
Pull-out internal structure
Structure interne extractible

6. Ripiano spostabile
Adjustable shelf
Étagère amovible

7. Frontale
Front panel
Façade

8. Maniglia
Handle
Poignée

OPTION

Cod. T593010

Cassetto estraibile porta cancelleria ad estrazione parziale
Partial-extension stationery drawer
Tiroir plumier extractible à extraction partielle

Cod. T593810

Telaio portacartelle ad estrazione totale
Full-extension filing frame
Châssis de classement à extraction totale

Cod. T593820

2 telai portacartelle ad estrazione totale + asta antibaltamento - Solo per CS0924
2 full-extension filing frame + anti-tilting bar - Only for CS0924
2 châssis de classement à extraction totale + tige anti-basculément - Seulement pour CS0924

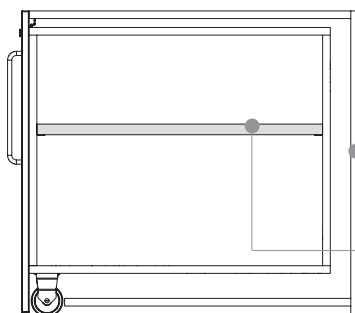

Struttura sp. 18 mm
18 mm th. structure
Structure ép. 18 mm

Ripiano spostabile sp. 25 mm
25 mm th. adjustable shelf
Étagère amovible ép. 25 mm

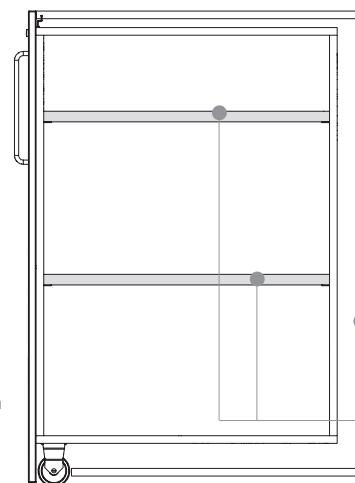

Struttura sp. 18 mm
18 mm th. structure
Structure ép. 18 mm

Ripiani spostabili sp. 25 mm
25 mm th. adjustable shelves
Étagères amovibles ép. 25 mm

Orgatower

Orgatower altezza scrivania - Scocca interna ad estrazione totale - Soft-closing system (incluso)

Desk-height orgatower - Full-extension inner structure - Soft-closing system (included)

Orgatower hauteur bureau - Structure interne à extraction totale - Soft-closing system (inclus)

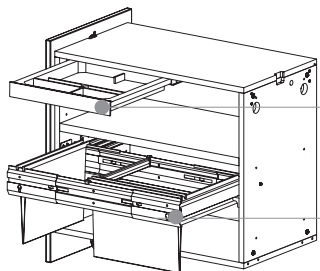
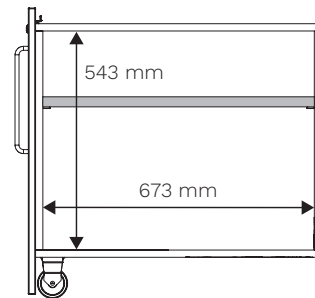
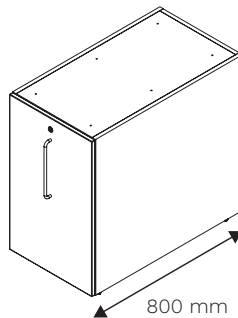
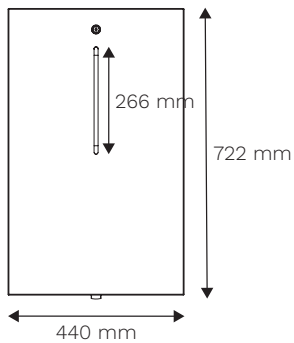

Cod. T593010
Cassetto porta cancelleria
ad estrazione parziale
Partial-extension stationery drawer
Tiroir plumier à extraction partielle

Cod. T593810
Telaio portacartelle
ad estrazione totale
Full-extension filing frame
Châssis de classement à extraction
totale

Sx
Lh

Orgatower H. 112 cm - Scocca interna ad estrazione totale - Soft-closing system (incluso)

H. 44*1/8 orgatower - Full-extension inner structure - Soft-closing system (included)

Orgatower Ht. 112 cm - Structure interne à extraction totale - Soft-closing system (inclus)

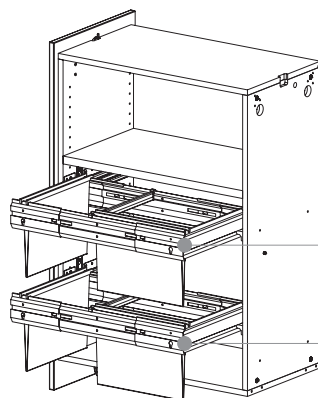
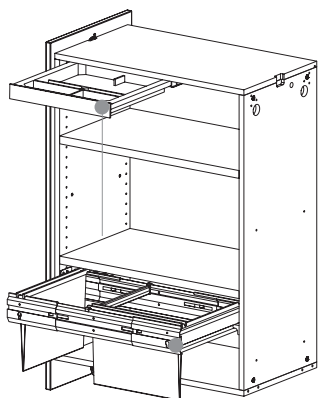
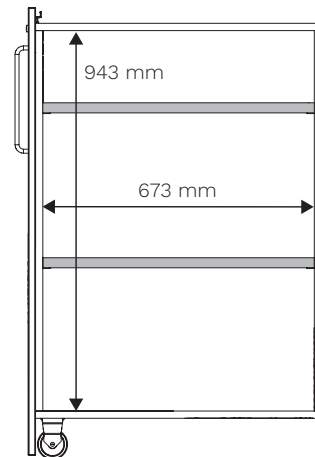
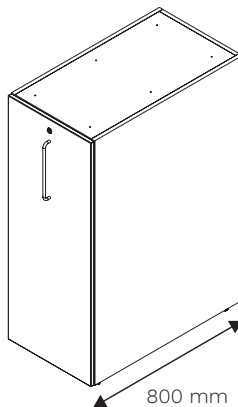
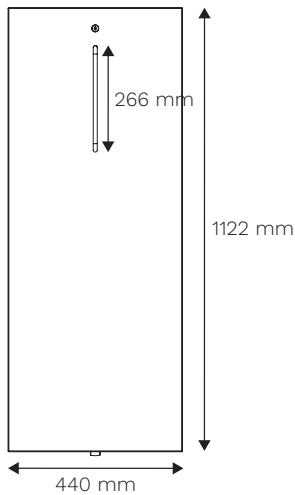

Cod. T593820
2 telai portacartelle ad estrazione totale
+ asta antiribaltamento - Solo per
CS0924
2 full-extension filing frame + anti-tilting
bar - Only for CS0924
2 châssis de classement à extraction
totale + tige anti-basculement -
Seulement pour CS0924

Sx
Lh

Sx
Lh

Orgatower

Telaio estraibile portacartelle

Pull-out filing frame

Châssis de classement extractible

COD.	Formato carta / Paper size	L. / W.	
421	B4 - US Legal	39,5 cm - 15"1/2	
420	A4 - US Letter	33 cm - 13"	

Con dotazione STANDARD archiviazione EUROPEA
EUROPEAN filing by standard outfit

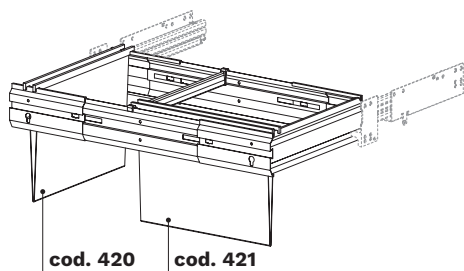

Cod. 420
33 cm - 13"
A4 - US Letter



Cod. 421
39,5 cm - 15"1/2
B4 - Foolscap - US Legal



Cod. 420
33 cm - 13"
A4 - US Letter

Cassetto porta cancelleria ad estrazione parziale

Partial-extension stationery drawer

Tiroir plumier à extraction partielle

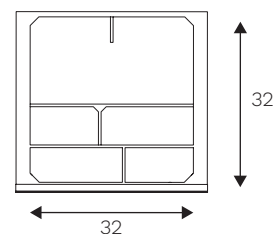
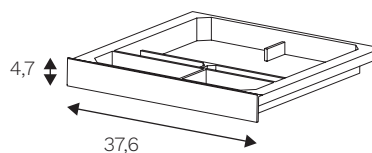
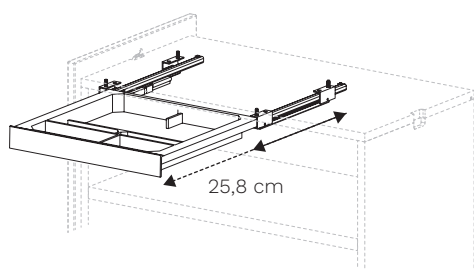

Orgatower

Costruzione codice

How to complete the code

Construction du code

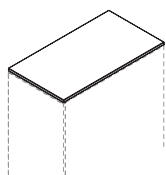
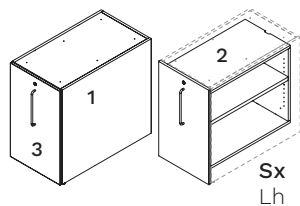

OPTIONS

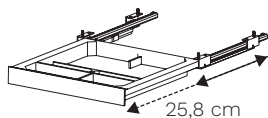

STEP 1

Codice articolo

Item code
Code article

(2) Finitura scocca interna estraibile

Finish for pull-out inner structure
Version structure interne extractible

CS0920 SX + MBI + MBI + MTR

(1) **Finitura scocca**
Finish for structure
Version structure

(3) **Finitura frontale**
Front finishing
Version du façade

STEP 2

Codice articolo

Item code
Code article

CS2928 + MTR

Finitura top
Top finishing
Version du dessus

STEP 3

Codice articolo

Item code
Code article

T593010 + NE

Finitura cassetto porta cancelleria

Finish for stationery drawer
Version tiroir plumier